

BACnet Integration for products using the AutoPhos Controller

About This Document

This document provides point list information for networking AutoPhos lighting panel controllers to a building automation system using the BACnet® data communication protocol.

BACnet® is a data communication protocol governing data exchange externally between digitally controlled building equipment devices and a building automation system. Digital functions within the equipment that are not part of the communication function are beyond the scope of BACnet. For *internal* configuration of the AutoPhos controller's advanced features, one must use the AutoPhos panel programming tool.

Network Addressing

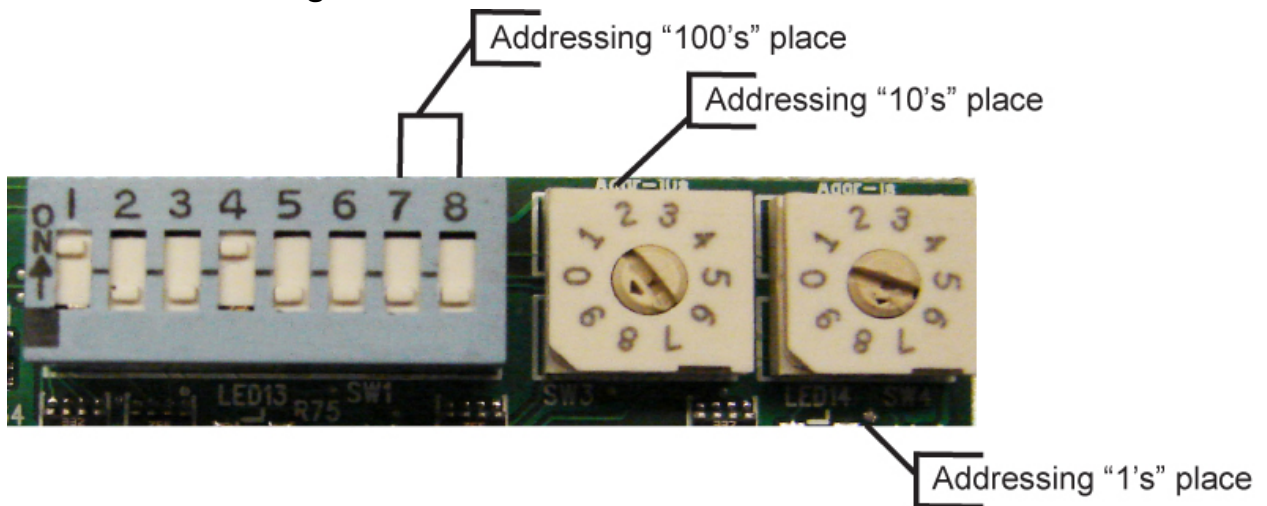

Using BACnet Device ID:

The AutoPhos will pick-up the rotary switch setting (located in the top right hand corner of the AutoPhos Controller) and append that value to the end of the Kele BACnet Vendor ID of 283:

2 8 3 0 X X

Valid Values for X X are 01 to 99.

Example:

Rotary switches are set to 1 and 2, respectively.

BACnet Device ID = 283012

Using AutoPhos MAC Address:

The AutoPhos will pick-up the rotary switch setting (located in the top right hand corner of the AutoPhos Controller):

X X

Valid Values for X X are 01 to 99.

Network Topography

The AutoPhos's multiple protocols including BACnet enable it to communicate with almost any BAS. The AutoPhos controller in your AutoPhos panel was factory-enabled with the mode specified at the time of order for your building automation system. All the point list information in this document is for BACnet MS/TP. BACnet MS/TP runs on an EIA-485 twisted pair network connecting the panels in a daisy chain topology without stars or t-taps.

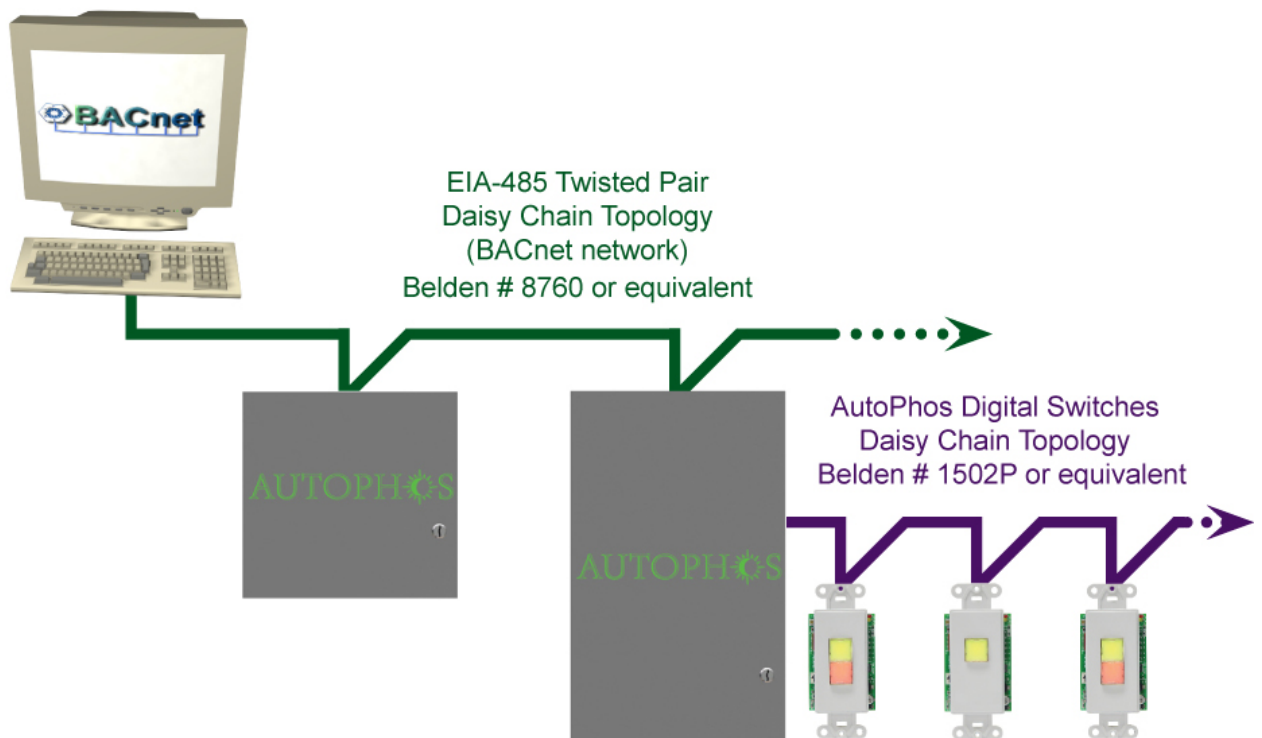

AutoPhos Internal Panel Features

The internal panel features are configured using the AutoPhos panel programming tool. An example of this is assigning relays to Groups. Actions taken on the panel Groups via BACnet communications will treat each Group as a whole and not be concerned with what has been configured “inside” the panel Group.

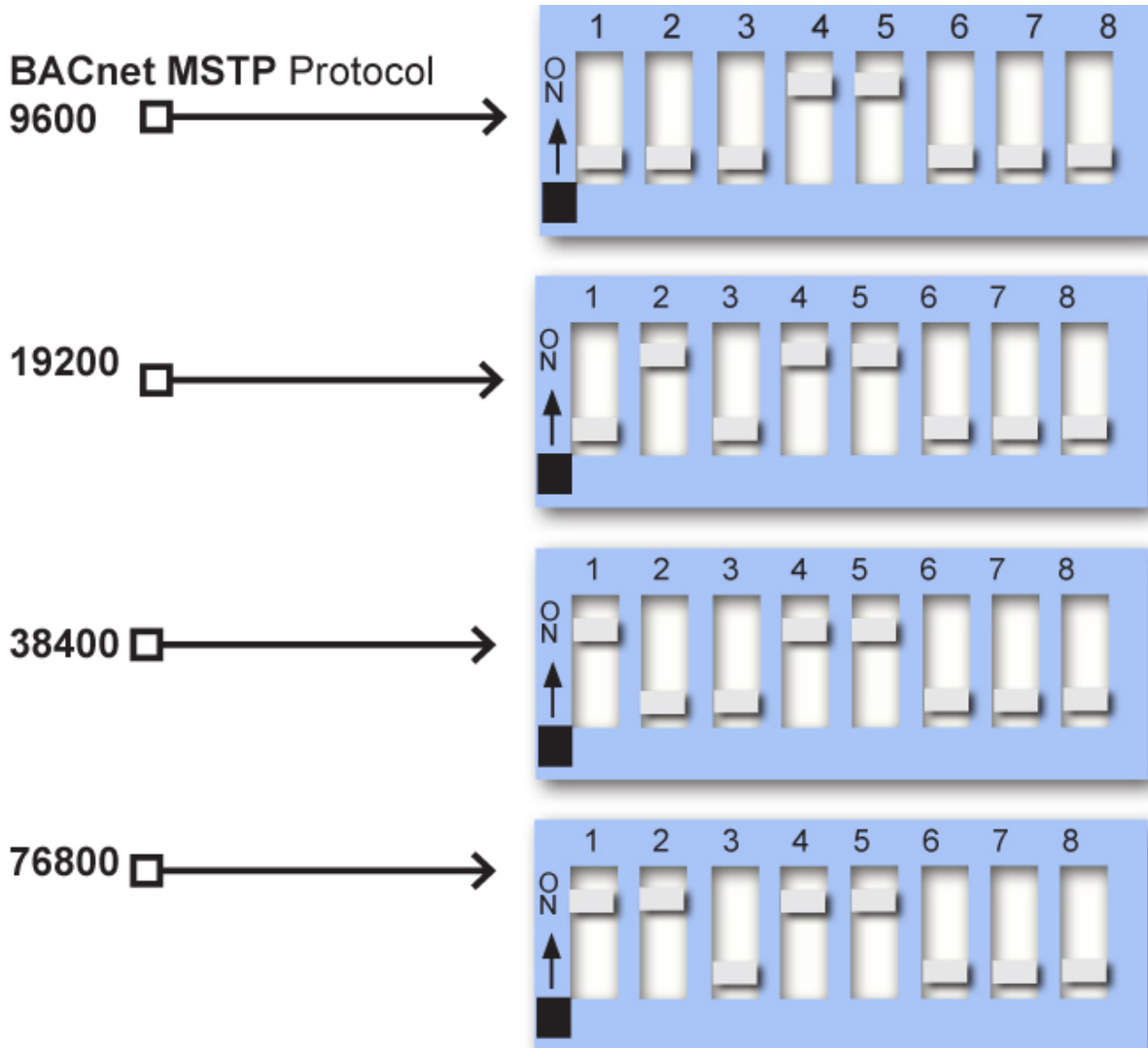

Point List Format, Definitions and Valid Ranges of Values

The BACnet points listed represent a standard BACnet control program with 60 lighting control zones. Each point named is described with a BACnet Type, Object ID, and Object Name. The Device ID is the BACnet device ID for the AutoPhos panel controller. "283" is the Kele BACnet Vendor ID assigned by ASHRAE.

Name	Type	Object ID	Object Name
Group Command - Binary	BBV	BV:1	schedule_1
Group Status - Binary	BBV	BV:101	b_groupstat_1
Group Command - MSV	BMSV	MSV:1	cmd_1
Group Status - MSV	BMSV	MSV:101	ms_groupstat_1
Group Timer	BAV	AV:1	timer_1

The AutoPhos controller has 5 standard communication objects:

1. Group Command
2. Group Status
3. Group Timer
4. Sensor Values
5. Relay status

The AutoPhos controller may also support the following communication object if those features are available in the product:

- Bad Relay Status

Group Information:

Group Command

The AutoPhos controller supports BACnet Binary (BV) or Multi State Values (MSV) for this communication object.

Binary (BV)

- 0 = OFF
- 1 = OFF

Multi-State Value (MSV)

- 1 = Do nothing (SS1)
- 2 = OFF with flash / blink warning (SS2)
- 3 = OFF
- 4 = ON

SS1 - This command is typically used for two reasons, scheduled OFF sweeps or manual ON / scheduled OFF control sequences.

Scheduled OFF sweeps - Prior to sending a BV for MSV for OFF to a group that has already received an OFF.

Manual ON / Schedule OFF - Allowing the occupants to manually turn on the lighting as they enter the space rather than scheduling it on is becoming common place. The MSV “DO Nothing” allows the building automation system to schedule “DO Nothing” rather than ON.

SS2 - This command is typically used by the BAS to execute a scheduled OFF function that includes

“flash / blink warning” for the occupants, Upon receipt of this MSV, the AutoPhos will turn the group OFF for 1 second and start the “on-time after flash” timer. The “on time after flash” timer is set using PANEL PROGRAMMING SOFTWARE, and is typically set to 10 minutes. When the “on time after flash” timer expires the group will turn OFF, unless the occupant has actuated a local override switch for that group

Group Status:

Binary (BV)

0 = OFF

1 = OFF

Multi-State Value (MSV)

1 = OFF due to serial command

2 = ON due to serial command

3 = OFF due to override switch

4 = ON due to override switch

5 = ON due to override switch with timer count

6 = ON due to manual override switch on AutoPhos

7 = OFF due to manual override switch on AutoPhos

Group Timer (in seconds):

Analog (AV)

Valid Values are 0 to 64,800

Note: AutoPhos controller supports Group Timers up to 18 hours (64,800 seconds).

Relay Status - Direct:

Multi-State Value (MSV)

1 = OFF

2 = ON

3 = OFF and bad*

4 = ON and bad*

* Note: Requires product with feedback hardware

Relay Status - Range:

Analog Value:

Valid values are 0 to 255

Example of de-multiplexed version:

An analog value of 123 is returned by the AutoPhos

That value converts to the following 8 bits:

Bit value		1	2	4	8	16	32	64	128
Bit#	1	2	3	4	5	6	7	8	
Converted value	1	1	0	1	1	1	1	0	

Relay status = 1, 2, 4, 5, 6 and 7 are ON

= 3 and 8 are OFF

Note: Requires de-multiplexer method to decompose analog value to relay status.

Sensor Information:

Sensor Values

Analog (AV)

Valid Values are 0 to 1024

Bad Relay - Range:

Analog Value:

Valid values are 0 to 255

Example of de-multiplexed version:

An analog value of 123 is returned by the AutoPhos

That value converts to the following 8 bits:

Bit value		1	2	4	8	16	32	64	128
	Bit#	1	2	3	4	5	6	7	8
Converted value		1	1	0	1	1	1	1	0

Relay status = 1, 2, 4, 5, 6 and 7 are BAD

= 3 and 8 are GOOD

Note: Requires de-multiplexer method to decompose analog value to relay status.

AutoPhos BACnet MS/TP Point List

Common

Name	Type	Object ID	Object Name
Common Alarms / Module Halted	EVT	BV:4000000	Module Halted Alarm
Common Alarms / All Programs Stopped	EVT	BV:4000001	All Programs Stopped Alarm
Common Alarms / Duplicate Address	EVT	BV:4000002	Duplicate Address Alarm
Common Alarms / Locked I/O	EVT	BV:4000003	Locked I/O Alarm
Common Alarms / Control Program	EVT	BV:4000004	Control Program Alarm

Group 1

Name	Type	Object ID	Object Name
Group Command Binary	BBV	BV:101	schedule_1
Group Status Binary	BBV	BV:1	b_groupstat_1
Group Command Multi State Value	BMSV	MSV:1	cmd_1
Group Status Multi State Value	BMSV	MSV:101	ms_groupstat_1
Group Timer	BAV	AV:1	timer_1

Group 2

Name	Type	Object ID	Object Name
Group Command Binary	BBV	BV:102	schedule_2
Group Status Binary	BBV	BV:2	b_groupstat_2
Group Command Multi State Value	BMSV	MSV:2	cmd_2
Group Status Multi State Value	BMSV	MSV:2	ms_groupstat_2
Group Timer	BAV	AV:102	timer_2

Group 3

Name	Type	Object ID	Object Name
Group Command Binary	BBV	BV:103	schedule_3
Group Status Binary	BBV	BV:3	b_groupstat_3
Group Command Multi State Value	BMSV	MSV:3	cmd_3
Group Status Multi State Value	BMSV	MSV:3	ms_groupstat_3
Group Timer	BAV	AV:103	timer_3

The pattern repeats, one group per output (relay) to group 60

Name	Type	Object ID	Object Name
Group Command Binary	BBV	BV:160	schedule_60
Group Status Binary	BBV	BV:60	b_groupstat_60
Group Command Multi State Value	BMSV	MSV:60	cmd_60
Group Status Multi State Value	BMSV	MSV:60	ms_groupstat_60
Group Timer	BAV	AV:160	timer_60

Relay Status – Direct

Relay 1 Status	BMSV	MSV:201	msrelay1stat_61
Relay 2 Status	BMSV	MSV:202	msrelay2stat_61
Relay 3 Status	BMSV	MSV:203	msrelay3stat_61
Relay 4 Status	BMSV	MSV:204	msrelay4stat_61
Relay 5 Status	BMSV	MSV:205	msrelay5stat_61
Relay 6 Status	BMSV	MSV:206	msrelay6stat_61
Relay 7 Status	BMSV	MSV:207	msrelay7stat_61
Relay 8 Status	BMSV	MSV:208	msrelay8stat_61
Relay 9 Status	BMSV	MSV:209	msrelay9stat_61
Relay 11 Status	BMSV	MSV:210	msrelay11stat_61
Relay 10 Status	BMSV	MSV:211	msrelay10stat_61
Relay 12 Status	BMSV	MSV:212	msrelay12stat_61
Relay 13 Status	BMSV	MSV:213	msrelay13stat_61
Relay 14 Status	BMSV	MSV:214	msrelay14stat_61
Relay 15 Status	BMSV	MSV:215	msrelay15stat_61
Relay 16 Status	BMSV	MSV:216	msrelay16stat_61
Relay 17 Status	BMSV	MSV:217	msrelay17stat_61
Relay 19 Status	BMSV	MSV:218	msrelay19stat_61
Relay 18 Status	BMSV	MSV:219	msrelay18stat_61
Relay 20 Status	BMSV	MSV:220	msrelay20stat_61
Relay 21 Status	BMSV	MSV:221	msrelay21stat_61
Relay 23 Status	BMSV	MSV:222	msrelay23stat_61
Relay 22 Status	BMSV	MSV:223	msrelay22stat_61
Relay 24 Status	BMSV	MSV:224	msrelay24stat_61
Relay 25 Status	BMSV	MSV:225	msrelay25stat_61
Relay 27 Status	BMSV	MSV:226	msrelay27stat_61
Relay 26 Status	BMSV	MSV:227	msrelay26stat_61
Relay 28 Status	BMSV	MSV:228	msrelay28stat_61
Relay 29 Status	BMSV	MSV:229	msrelay29stat_61
Relay 31 Status	BMSV	MSV:230	msrelay31stat_61
Relay 30 Status	BMSV	MSV:231	msrelay30stat_61
Relay 32 Status	BMSV	MSV:232	msrelay32stat_61
Relay 33 Status	BMSV	MSV:233	msrelay33stat_61
Relay 35 Status	BMSV	MSV:234	msrelay35stat_61
Relay 34 Status	BMSV	MSV:235	msrelay34stat_61
Relay 36 Status	BMSV	MSV:236	msrelay36stat_61
Relay 37 Status	BMSV	MSV:237	msrelay37stat_61

The pattern repeats, one group per output to Relay 60

Relay 52 Status	BMSV	MSV:252	msrelay52stat_61
Relay 53 Status	BMSV	MSV:253	msrelay53stat_61
Relay 55 Status	BMSV	MSV:254	msrelay55stat_61
Relay 54 Status	BMSV	MSV:255	msrelay54stat_61
Relay 56 Status	BMSV	MSV:256	msrelay56stat_61
Relay 57 Status	BMSV	MSV:257	msrelay57stat_61
Relay 59 Status	BMSV	MSV:258	msrelay59stat_61
Relay 58 Status	BMSV	MSV:259	msrelay58stat_61
Relay 60 Status	BMSV	MSV:260	msrelay60stat_61

Relay Status – Range

Relays Status 1-8	BAV	AV:201	relays_1-8_61
Relays Status 9-16	BAV	AV:202	relays_9-16_61
Relays Status 17-24	BAV	AV:203	relays_17-24_61
Relays Status 25-32	BAV	AV:204	relays_25-32_61
Relays Status 33-40	BAV	AV:205	relays_33-40_61
Relays Status 41-48	BAV	AV:206	relays_41-48_61
Relays Status 49-56	BAV	AV:207	relays_49-56_61
Relays Status 57-60	BAV	AV:208	relays_57-60_61

Sensor Values

Analog Input 1	BAV	AV:101	ai1_61
Analog Input 2	BAV	AV:102	ai2_61
Analog Input 3	BAV	AV:103	ai3_61
Analog Input 4	BAV	AV:104	ai4_61
Analog Input 5	BAV	AV:105	ai5_61
Analog Input 6	BAV	AV:106	ai6_61

BAD Relay – Range (provided the product supports)

BAD Relays 1-8	BAV	AV:301	bad_1-8_61
BAD Relays 9-16	BAV	AV:302	bad_9-16_61
BAD Relays 17-24	BAV	AV:303	bad_17-24_61
BAD Relays 25-32	BAV	AV:304	bad_25-32_61
BAD Relays 33-40	BAV	AV:305	bad_33-40_61
BAD Relays 41-48	BAV	AV:306	bad_41-48_61
BAD Relays 49-56	BAV	AV:307	bad_49-56_61
BAD Relays 57-60	BAV	AV:308	bad_57-60_61
reset	BBV	BV:200	reset_61
Bad Relay	BBV	BV:201	